

Product Brief



WIDE BANDGAP

GaN FETs

40V to 700V
11.5A to 100A



Combining high voltage capability with low $r_{DS(ON)}$, Central's N-Channel GaN FETs are designed for high frequency applications with high standards of efficiency. These GaN FETs are offered in 100V that supports 60A or 650V that supports 11A or 17A and are provided in a variety of low profile surface-mount and chip scale packages. Bare die are also available.

Features

- High voltage capability (700V)
- Low gate charge & $r_{DS(ON)}$ (as low as 3.2m Ω)
- Efficient fast switching
- Space-saving DFN and CSP
- Also available as bare die

Applications

- Alternative energy inverters
- Battery Management Systems (BMS)
- High efficiency power supplies
- Electric vehicle charging

Benefits

- Low conduction losses
- High frequency switching capability
- High power density

LOW VOLTAGE

Central Item No.	Maximum Ratings ($T_A = 25^\circ\text{C}$ unless otherwise noted)					Electrical Characteristics: ($T_A = 25^\circ\text{C}$ unless otherwise noted)					Package	Central Die Item No.
	V_{DS} (V) MAX	V_{GS} (V) MAX	I_D (A) MAX	I_{DM} (A) MAX	T_J, T_{stg} ($^\circ\text{C}$) MAX	$r_{DS(ON)}$ (m Ω) MAX	$V_{GS(th)}$ (V) MAX	Q_g (nC) TYP	Q_{gd} (nC) TYP	Q_{gs} (nC) TYP		
CCSPG0420N*	40	6.0	20	100	-40 to +125	4.0	2.4	15.8	8.6	1.9	CSP2X2	CPG005
CCSPG0450N*	40	-4.0 to +6.0	50	200	-40 to +150	1.5	2.3	28	4.6	6.2	CSP5X4	CPG006
CCSPG1060N	100	-4.0 to +8.0	60	-	-40 to +150	5.5	2.5	9.2	1.9	1.7	CSP3.5X2	CPG001
NEW CCSPG1560N*	150	-4.0 to +6.0	60	-	-40 to +150	7.0	2.1	13	2.0	3.0	CSP4X6	CPG008
NEW CCSPG1510N*	150	-4.0 to +6.0	100	-	-40 to +150	3.9	2.1	20	3.5	5.0	CSP4X6	CPG009

HIGH VOLTAGE

Central Item No.	Maximum Ratings ($T_A = 25^\circ\text{C}$ unless otherwise noted)					Electrical Characteristics: ($T_A = 25^\circ\text{C}$ unless otherwise noted)					Package	Central Die Item No.
	V_{DS} (V) MAX	V_{GS} (V) MAX	I_D (A) MAX	I_{DM} (A) MAX	T_J, T_{stg} ($^\circ\text{C}$) MAX	$r_{DS(ON)}$ (m Ω) MAX	$V_{GS(th)}$ (V) MAX	Q_g (nC) TYP	Q_{gd} (nC) TYP	Q_{gs} (nC) TYP		
CDF56G6511N	650	-1.4 to +7.0	11.5	20.5	-55 to +150	190	2.5	2.8	1.1	0.25	DFN5X6A	CPG003
CDF56G6517N	650	-1.4 to +7.0	17	32	-55 to +150	140	2.5	3.5	1.2	0.3	DFN5X6A	CPG004
CDFG6511N*	650	-1.4 to +7.0	11.5	20.5	-55 to +150	190	2.5	2.8	1.1	0.25	DFN8X8	CPG003
CDFG6517N*	650	-1.4 to +7.0	17	32	-55 to +150	140	2.5	3.5	1.2	0.3	DFN8X8	CPG004
NEW CDFG6558N*	650	-6.0 to +7.0	29	58	-55 to +150	80	2.5	6.2	2.2	0.5	DFN8X8	CPG010
NEW CDF56G7032N*	700	-6.0 to +7.0	18	32	-55 to +155	140	2.5	3.5	1.2	0.3	DFN5X6A	CPG011

*Available on demand

GaN FETs

40V to 700V, 11.5A to 100A

CSP3.5X2

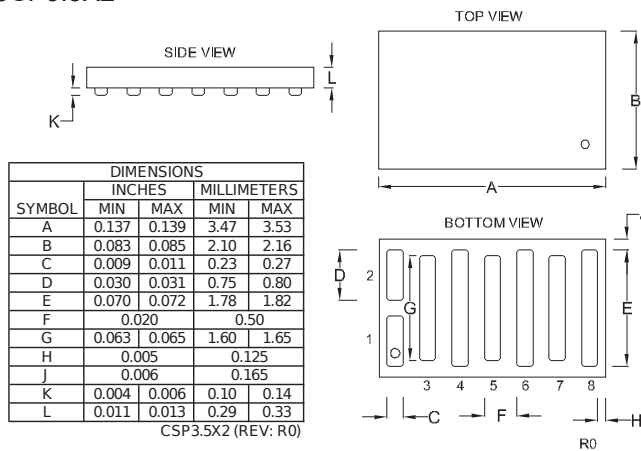

CSP2X2

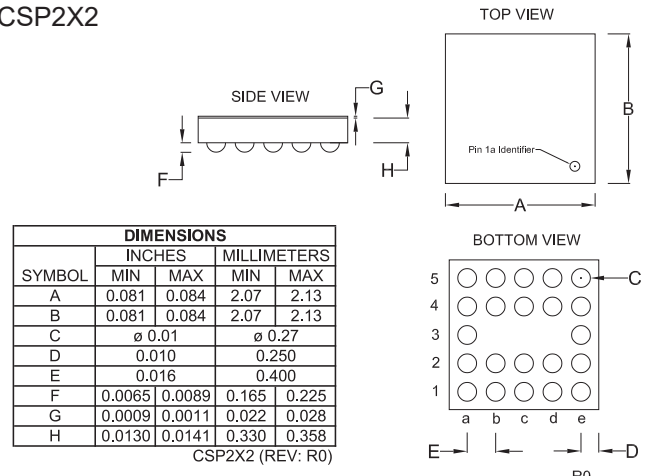

DFN5X6A

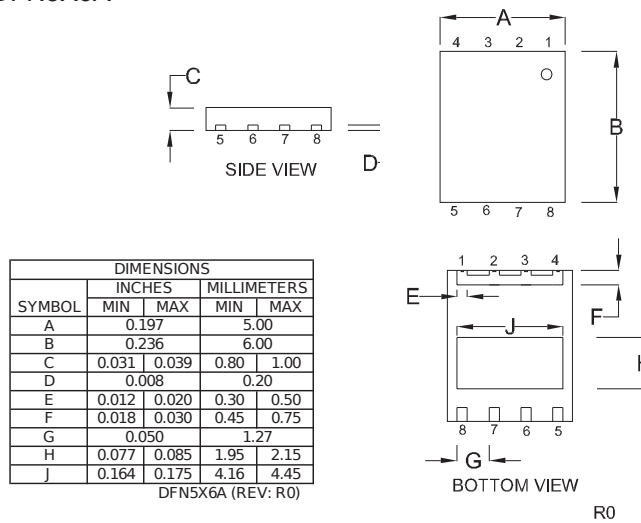

CSP5X4

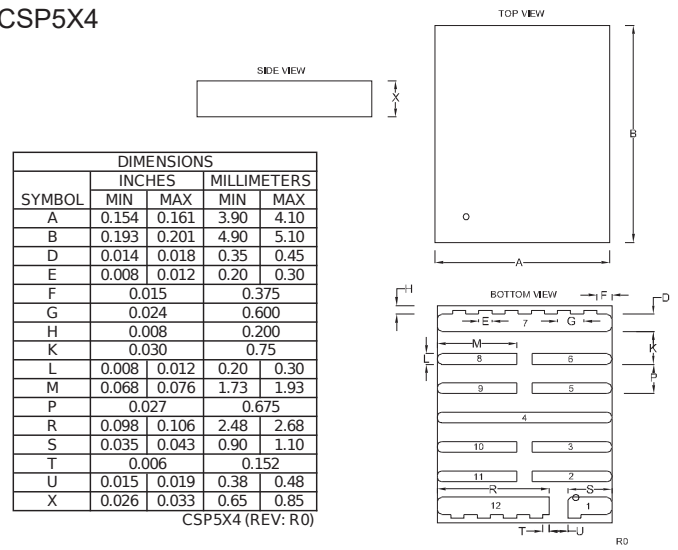

DFN8X8

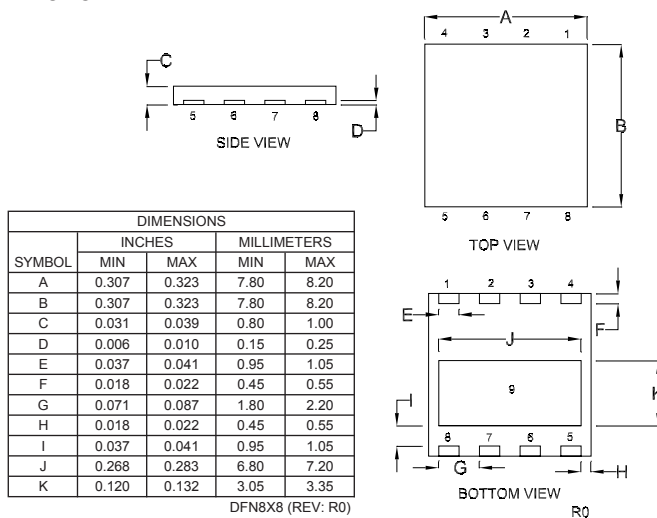

CSP4X6

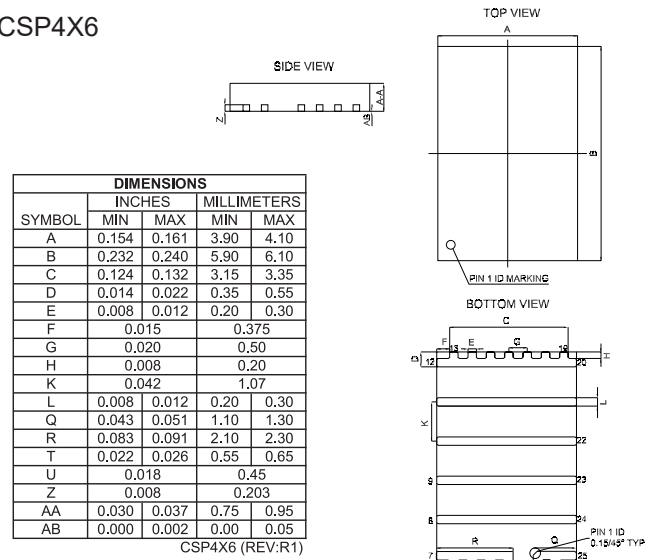

For more information on Central's products and potential solutions:

Call us at: **1.631.435.1110**

Or view online: www.centrasemi.com/featured-products

