

Product Brief



WIDE BAND GAP

Gallium Nitride (GaN) N-Channel FETs

100V | 60A
650V | 11A, 17A

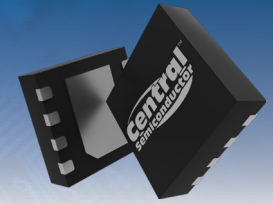

Combining high voltage capability with low $r_{DS(ON)}$, Central's N-Channel GaN FETs are designed for soft switching applications with high standards of efficiency. These GaN FETs are offered in 100V that supports 60A or 650V that supports 11A or 17A are provided in a variety of practical surface-mount and chip scale packages. Bare dies are also available.

Features

- High voltage capability (650V)
- Low gate charge & $r_{DS(ON)}$ (as low as 3.2m Ω)
- Efficient fast switching
- Space-saving DFN and CSP
- Also available as bare die

Applications

- Wireless charging (high power)
 - Defense/aerospace
 - Healthcare
 - Consumer
- Power Factor Correction (PFC)
- Electric vehicle inverters

Benefits

- Minimal power loss in conduction
- High frequency switching capability
- No reverse recovery losses

Central Item No.	Maximum Ratings ($T_A = 25^\circ\text{C}$ unless otherwise noted)					Electrical Characteristics: ($T_A = 25^\circ\text{C}$ unless otherwise noted)					Package	
	V_{DS} (V) MAX	V_{GS} (V) MAX	I_D (A) MAX	I_{DM} (A) MAX	T_J, T_{stg} ($^\circ\text{C}$) MAX	$r_{DS(ON)}$ MAX	$V_{GS(th)}$ MAX	Q_g TYP	Q_{gd} TYP	Q_{gs} TYP		
CCSPG1060N	100	-4.0 to +8.0	60	230	-40 to +150	3.2	2.5	1.9	1.7	1.1	CSP3.5X2	
CDF56G6511N	650	-1.4 to +7.0	11.5	20.5	-55 to +150	190	2.5	2.8	1.1	0.25	DFN5X6A	
CDF56G6517N	650	-1.4 to +7.0	17	32	-55 to +150	140	2.5	3.5	1.2	0.3	DFN5X6A	
CDFG6511N*	650	-1.4 to +7.0	11.5	20.5	-55 to +150	190	2.5	2.8	1.1	0.25	DFN8X8	
CDFG6517N*	650	-1.4 to +7.0	17	32	-55 to +150	140	2.5	3.5	1.2	0.3	DFN8X8	
CCSPG0420N*	40	6.0	20	100	-40 to +150	4.0	2.4	15.8	8.6	1.9	CSP2X2	
CCSPG0450N*	40	-4.0 to +6.0	50	200	-40 to +150	1.2	2.3	2.8	4.6	6.2	CSP5X4	

*Available on demand

Bare Die - Available on Demand						
Central Die Item No.	Central Pkg. Device Item #	Die Size / MILS	Die Thickness	Topside Metalization	Backside Metalization	Chip Tray Pkg. Base
CPG007	CCSPG1060N	138.9 X 85	46.02	Ai-Cu 35000 Å	Si 21000 Å	88
CPG003	CDF56G6511N CDFG6511N*	132 X 55	45.2	Ai-Cu 35000 Å	Si 21000 Å	104
CPG004	CDF56G6517N CDFG6517N*	165 X 65	45.2	Ai-Cu 35000 Å	Si 21000 Å	60

Gallium Nitride (GaN) FETs

100V | 60A , 650V | 11A, 17A

CSP3.5X2

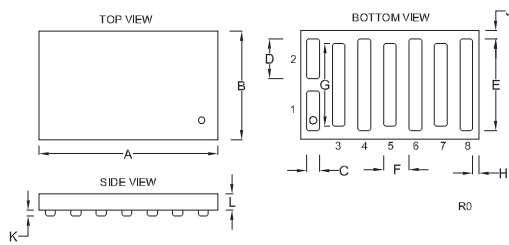

LEAD CODE:

- 1) Gate 5) Drain
- 2) Source 6) Source
- 3) Drain 7) Drain
- 4) Source 8) Source

MARKING: CSP 1060

SYMBOL	DIMENSIONS			
	INCHES		MILLIMETERS	
	MIN	MAX	MIN	MAX
A	0.137	0.139	3.47	3.53
B	0.083	0.085	2.10	2.16
C	0.009	0.011	0.23	0.27
D	0.030	0.031	0.75	0.80
E	0.070	0.072	1.78	1.82
F	0.020		0.50	
G	0.063	0.065	1.60	1.65
H	0.005		0.125	
J	0.006		0.165	
K	0.004	0.006	0.10	0.14
L	0.011	0.013	0.29	0.33

CSP3.5X2 (REV: R0)

DFN5X6A

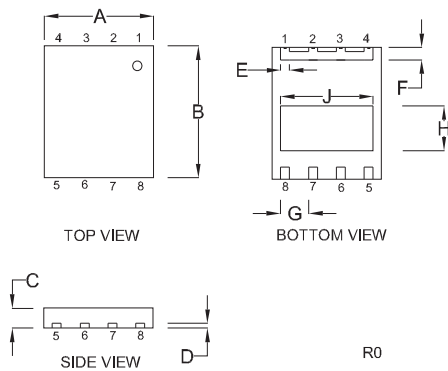

PIN CONFIGURATION

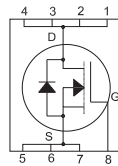

LEAD CODE:

- 1) Drain 5) Source
- 2) Drain 6) Source
- 3) Drain 7) Kelvin Source
- 4) Drain 8) Gate

Pins 5, 6, 7 are common to the pad

MARKING: C6517 5X6 L/C D/C

SYMBOL	DIMENSIONS			
	INCHES		MILLIMETERS	
	MIN	MAX	MIN	MAX
A	0.197		5.00	
B	0.236		6.00	
C	0.031	0.039	0.80	1.00
D	0.008		0.20	
E	0.012	0.020	0.30	0.50
F	0.018	0.030	0.45	0.75
G	0.050		1.27	
H	0.077	0.085	1.95	2.15
J	0.164	0.175	4.16	4.45

DFN5X6A (REV: R0)

DFN8X8

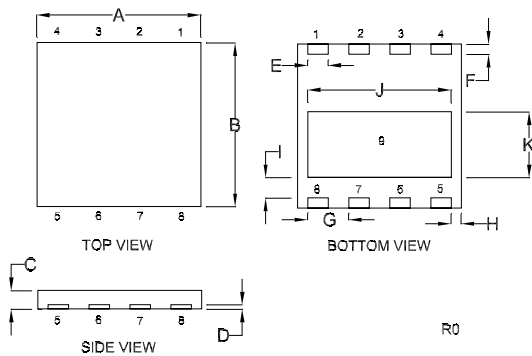

PIN CONFIGURATION

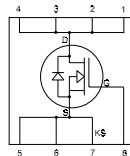

LEAD CODE:

- 1) Drain 5) Source
- 2) Drain 6) Source
- 3) Drain 7) Kelvin Source
- 4) Drain 8) Gate

Pins 5, 6, 7 are common to the pad (9)

MARKING: C6511 L/C D/C

SYMBOL	DIMENSIONS			
	INCHES		MILLIMETERS	
	MIN	MAX	MIN	MAX
A	0.307	0.323	7.80	8.20
B	0.307	0.323	7.80	8.20
C	0.031	0.039	0.80	1.00
D	0.006	0.010	0.15	0.25
E	0.037	0.041	0.95	1.05
F	0.018	0.022	0.45	0.55
G	0.071	0.087	1.80	2.20
H	0.018	0.022	0.45	0.55
I	0.037	0.041	0.95	1.05
J	0.268	0.283	6.80	7.20
K	0.120	0.132	3.05	3.35

DFN8X8 (REV: R0)

SPICE Models and other technical resources:

Visit www.centalsemi.com to download SPICE models for these devices.

RoHS and REACH compliance declarations

Visit the Quality section of Central's website to access.

For more information on Central's products and potential solutions:

Call us at: **1.631.435.1110**

Or view online: www.centalsemi.com/featured-products

